







KESSEL-Sägeglocke

KESSEL.store

Hole saw • scie cloche • sega a tazza • gatenzaag • wyrzynarka

Allgemeine Sicherheitshinweise / General safety notes / Consignes de sécurité générales / Indicazioni sulle presenti istruzioni / Algemene veiligheidsinstructies / Ogólne wskazówki bezpieczeństwa	
	Vorgeschriebene persönliche Schutzausrüstung / Prescribed personal protective equipment / Équipement de protection personnel prescrit / Dispositivi di protezione individuale prescritti / Voorgeschreven persoonlijke beschermingsmiddelen / Przepisowe wyposażenie ochrony indywidualne
	
	heiße Oberfläche / hot surfaces / surfaces chaudes / superfici calde hete oppervlakken / gorąca powierzchnia

Icon	Bedeutung / Meaning / Signification / Significato / Betekenis/ Znaczenie
	Systemübersicht / System overview / Quadro del sistema / vue d'ensemble du système / systeemoverzicht / Przegląd systemu
	Zubehör / Accessories / Accessoires / Accessori / Onderdelen / Części
	Einbau / Installation / Montage / Montaggio / Montage / Montaż



Art.: 500100

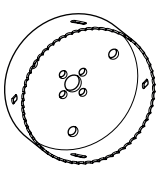
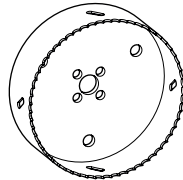
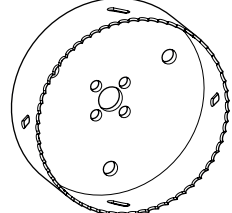
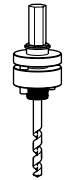





DN 100
Ø 121mm

DN 125
Ø 133mm

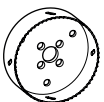
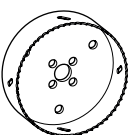
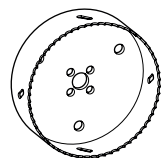
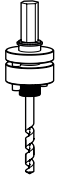
DN 150
Ø 168mm

Art.: 500101







DN 50
Ø 60mm

DN 70
Ø 92mm

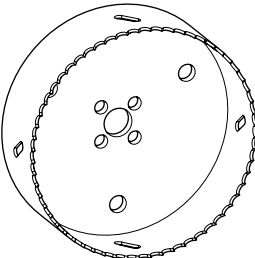
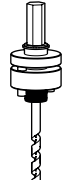

DN 100
Ø 121mm

Art.: 500102

DN 200
Ø 210mm





DN 200
Art.: 850123

DN 150
Art.: 850119



DN 125
Art.: 850118

DN 100
Art.: 850117

DN 70
Art.: 850116



DN 50
Art.: 850114

DN 50
Art.: 39005

DN 70
Art.: 39007

DN 100
Art.: 39100

Nr. 028-004

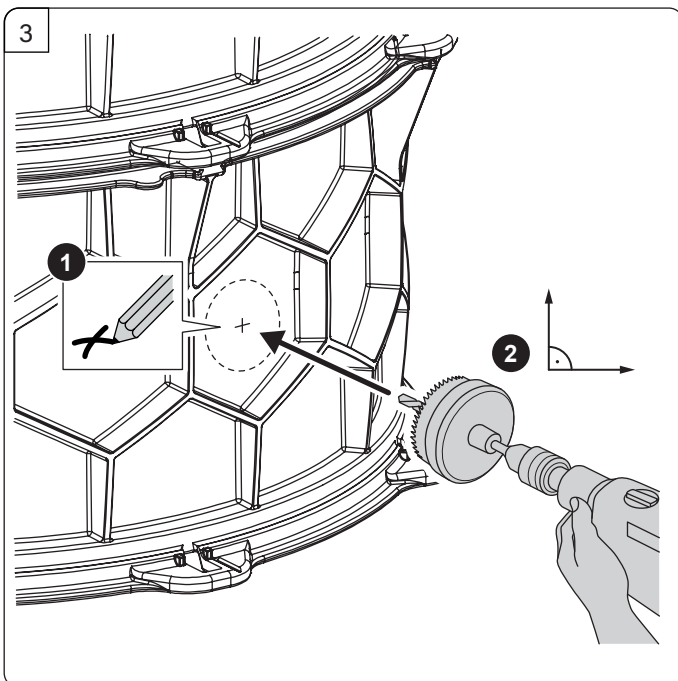
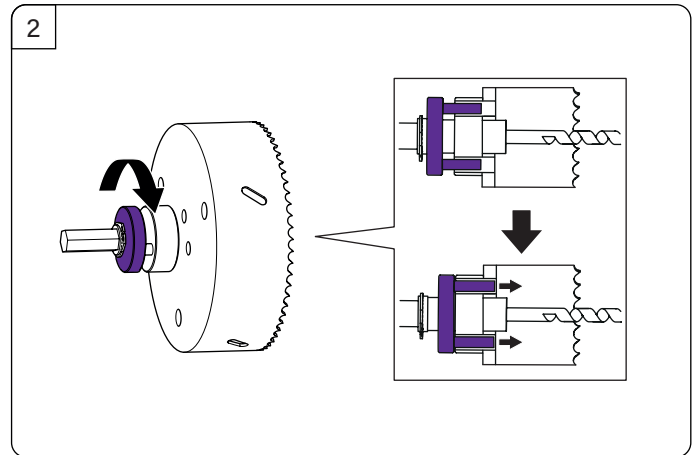
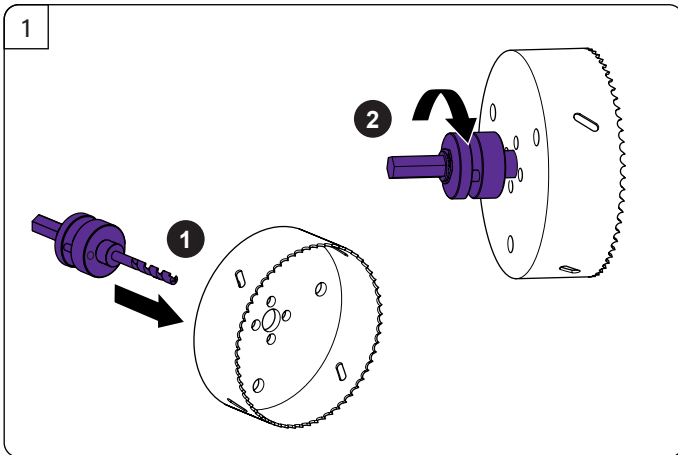

DE: Bohrer senkrecht ansetzen und mit wenig Vorschub aber hohem Drehmoment Schnitt ansetzen

EN: Set drill in perpendicular angle without much force but high torque.

FR: Positionner la perceuse perpendiculairement, commencer à percer sans trop forcer mais avec un couple élevé.

IT: Posizionare la punta del trapano verticalmente e tagliare con poca alimentazione ma coppia elevata.

NL: Boor haaks plaatsen en met weinig druk, maar hoog draaimoment gat voorzien.

PL: Ustaw wiertło prostopadle do wierzonego otworu. Podczas wiercenia nie używaj dużej siły dociskając wiertarkę. Wiertarkę ustaw na wysokie obroty.

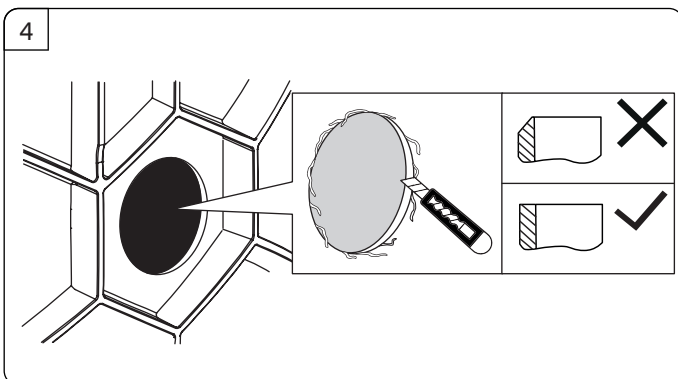

DE: Späne entfernen, Bohrung aber nicht entgraten

EN: Remove chips manually but do not deburr.

FR: Retirer les copeaux, mais ne pas ébavurer.

IT: Rimuovere i trucioli, ma non sbavare il foro.

NL: Spaanders verwijderen, maar niet afbramen.

PL: Usuń opilki po wierceniu ale nie fazuj krawędzi otworu.

